

## 2 temperature instrumentation

---

# 2. temperature

## 2.2. temperature sensors

### 2.2.1. thermocouples

traditional insulation thermocouples		135
MgO mineral insulated thermocouples		135
interchangeable thermocouple	BDTIC	136
interchangeable thermocouple	BDTIM	136
interchangeable thermocouple	BDTTG	136
immersion thermocouple	BDTRG	136
thermocouple for immersion	BDTTF	136
immersion thermocouples with MgO insulated	BDTRF	136
thermocouple suitable for mounting	BDTTI	136
spring-loaded thermocouples	BDTBA	137
spring-loaded thermocouple	BDTM	137
spring-loaded thermocouples	BDTBF	137
spring-loaded thermocouple	BDTBS	137
thermocouple with stainless steel	BDTLF	137
free rotating nut thermocouple	BDTBL	137
thermocouple for high pressure	BDTMT	137
cylindrical thermocouple with AISI 304	BDTLM	138
cylindrical thermocouple with stainless steel	BDTMM	138
cylindrical thermocouple with AISI 304 sheath	BDTLR	138
thermocouple with stainless steel sheath suitable	BDTOT	138
mineral oxide MgO insulated thermocouples	BDTCM	138
conventional insulated thermocouple ( TIC )	BDTTS	138
thermocouple with mineral oxide insulation for	BDTTM	138
thermocouple suitable	BDTTP	139
thermocouple for high temperature	BDTTH	139
thermocouple for high temperature	BDTTV	139

### 2.2.2. resistance-elements

RTD with stainless steel point	BDRLF	141
RTD with stainless steel point	BDRMF	141
RTD to measure surface temperatures	BDRLB	141
interchangeable RTD insert with standard	BDRIS	141
interchangeable RTD insert with mineral oxide	BDRIM	141
RTD for direct immersion with interchangeable	BDRTG	141
immersion RTD with interchangeable	BDRRG	141
RTD for immersion with interchangeable	BDRTF	141
cylindrical RTD with AISI304 sheath	BDRLM	142
cylindrical RTD with stainless steel sheath	BDRMM	142
cylindrical RTD with AISI 304 sheath	BDRLR	142
RTD with stainless steel sheath	BDROT	142
RTD for direct immersion with connection head	BDRTS	142
RTD with mineral oxide	BDRTM	142
spring-loaded RTD	BDRBA	142
spring-loaded RTD	BDRBS	142
immersion RTD with MgO insulated	BDRRF	143
RTD suitable for mounting - thermowell	BDRTI	143
RTD suitable for mounting - thermowell	BDRTP	143
RTD for direct immersion with AISI316 sheath	BDRTA	143
RTD probe for the measurement of internal	BDRAL	143
RTD probe for the measurement	BDRAB	143

# instrumentation index

---

---

temperature sensors

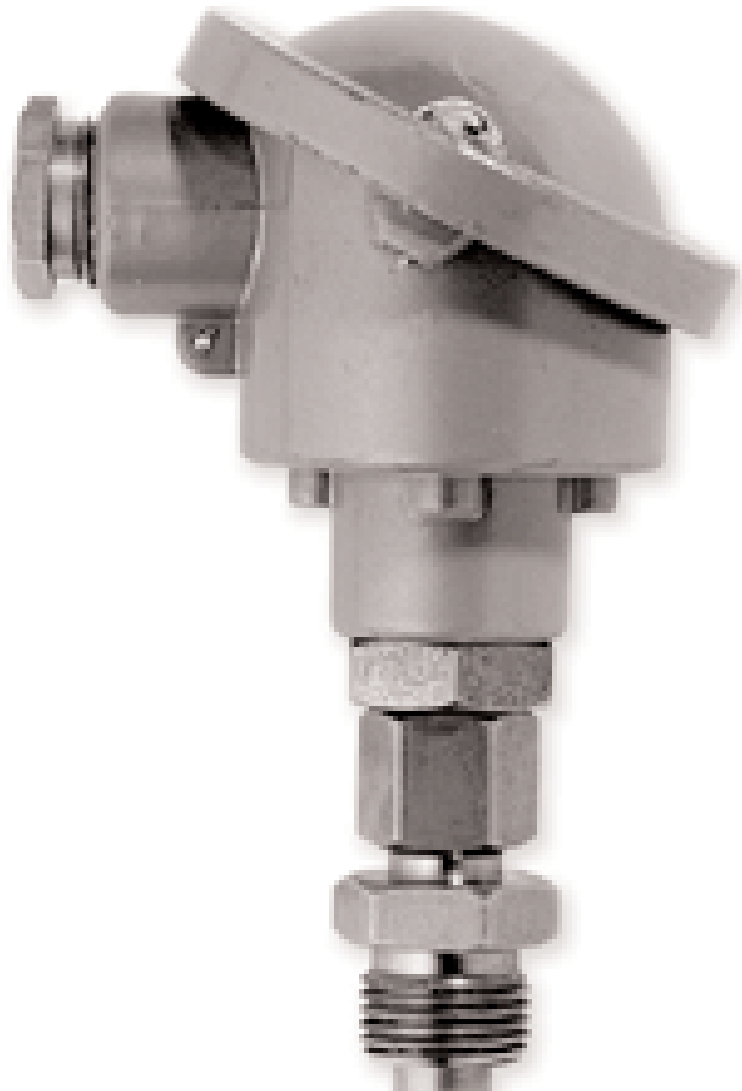

## thermocouples

Thermocouples are pairs of dissimilar metal wires joined at least at one end, which generate a thermo-electric voltage between the open pair according to the size of the temperature difference between the ends, the relative Seebeck coefficient of the wire pair and the uniformity of the wire pair relative Seebeck coefficient.

### Traditional insulation thermocouples

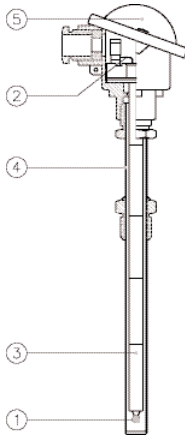

#### 1) measuring junction

the measuring junction or hot junction is the area in which the two conductors are joined together. This junction must be created in such a way that there is no mechanical stress on the two conductors.

#### 2) thermocouple wires

the thermocouple must be of appropriate dimensions for the conditions of use, it is possible to insert two or more thermocouples into the same probe.

#### 3) ceramic insulators

ceramic insulators are used to keep the thermocouple wires insulated along the entire length of the probe both from each other and the external sheath.

#### 4) protective sheath

the protective sheath is designed to protect and isolate the thermocouple from the process. A correct choice of materials and thickness is important against process conditions. In certain conditions it is recommended to use thermowells.

#### 5) connection head

the connection head contains the wiring terminals made of ceramic insulating material. Depending on the conditions an Ex proof execution can be supplied. A build in 4-20 mA transmitter is available, this can be mounted instead of the ceramic block.

### MgO mineral insulated thermocouples

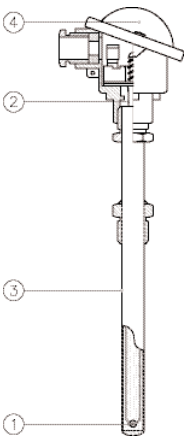

#### 1) measuring junction

special techniques are used to create the joint between the two conductors forming the thermocouple inside the mineral oxide insulation cable. The measuring junction is normally supplied with insulated junctions but is also available in a grounded version or can be provided with an exposed junction when a fast response time is required.

#### 2) thermocouple wires

inside the mineral oxide insulation cable there can be two/four or six wires.

#### 3) sheath with mineral insulation

this consists of a metal sheath containing the conductors which are insulated from each other and from the sheath itself by extremely pure and highly compressed metal oxide, Standard magnesium oxide ( MgO ) is used for isolation.

#### 4) connection head

the connection head contains the wiring terminals made of ceramic insulating material. Depending on the conditions an Ex proof execution can be supplied. A build in 4-20 mA transmitter is available, this can be mounted instead of the ceramic block.

Exposed hot junction



Fast response time

Grounded hot junction



high pressure 3500 bar

Insulated hot junction



with non-isolated instruments

## thermocouples

2.2.1.

temperature sensors



### Type BDTIC

Interchangeable thermocouple insert with ceramic insulation suitable for use in assembly type BDTS etc.



### Type BDTIM

Interchangeable thermocouple insert with mineral oxide MgO insulation suitable for use in assembly type BDTRG etc.

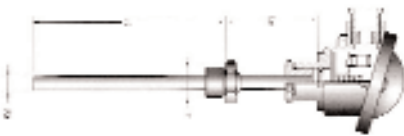

### Type BDTTG

Thermocouple for direct immersion with interchangeable thermocouple insert ( type BDTIM ) and revolving connection head suitable for measurements and controls on plants with low pressure.

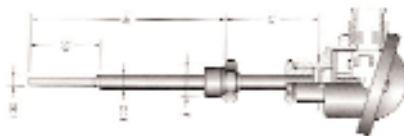

### Type BDTRG

Immersion thermocouple with interchangeable MgO insulated thermocouple insert ( type BDTIM ), revolving connection head and tapered protective sheath for fast response time, for measurement and controls on plants with low pressure.

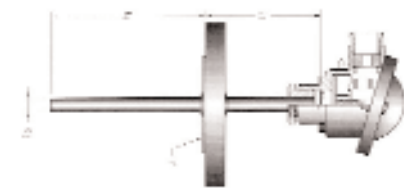

### Type BDFFF

Thermocouple for immersion with interchangeable thermocouple insert ( type BDTIM ) and revolving connection head for measurements and controls on plants with low pressure.

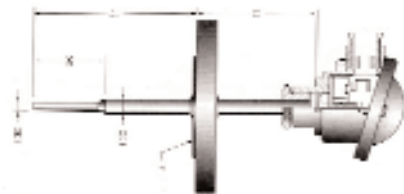

### Type BDTRF

Immersion thermocouples with MgO insulated interchangeable thermocouple insert ( type BDTIM ), revolving connection head and stepped protective sheath for fast response time, for measurements and controls on plants with low pressure.

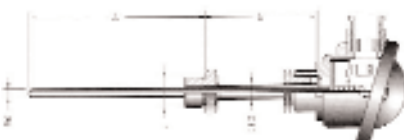

### Type BDTTI

Thermocouple suitable for mounting together with thermowells ( see page 152, 153, 154 ), for temperature measurements on industrial plants with high pressure.

**Type BDTBA**

Spring-loaded thermocouples designed for measurements into metallic plates; the mounting is done by threaded connection with bayonet fitting.



**Type BDTM**

Spring-loaded thermocouple for measurements into metallic plates with mineral oxide MgO insulation; the mounting is done by a threaded connection with bayonet fitting.



**Type BDTBF**

Spring-loaded thermocouples for measurement into metallic plates; the mounting is done by threaded connection with bayonet fitting and with adjustable immersion length.



**Type BDTBS**

Spring-loaded thermocouple for measurements into metallic plates, the mounting is done by a threaded connection with bayonet fitting; this probe is especially designed for spots with space problems.



**Type BDTLF**

Thermocouple with stainless steel point to measure temperatures in meat etc.



**Type BDTBL**

Free rotating nut thermocouple suitable for temperature monitoring and controls of heating plates and blocks.



**Type BDTMT**

Thermocouple for high pressure and fast response time suitable for the plastic industry.

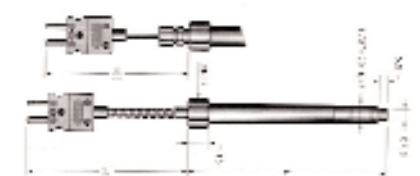

## thermocouples

2.2.1.

In this catalogue we give you just an overview on our thermocouple sensors and resistance sensors, due to the many varieties in executions we limit this to the standard items, for items not mentioned in the catalogue we ask you to consult us.

temperature sensors



### Type BDTLM

Cylindrical thermocouple with AISI 304 sheath suitable for general measurements and controls.



### Type BDTMM

Cylindrical thermocouple with stainless steel sheath and with compact mineral oxide ( MgO ) insulation.



### Type BDTLR

Cylindrical thermocouple with AISI 304 sheath suitable for general measurements and controls. The fixing is done by means of a threaded connection welded on the sheath.



### Type BDTOT

Thermocouple with stainless steel sheath suitable for general measurements and controls. The sensor fixing is done by means of a brass ring soldered on the tip of the tube.



### Type BDTCM

Mineral oxide MgO insulated thermocouples for general and laboratory measurements.

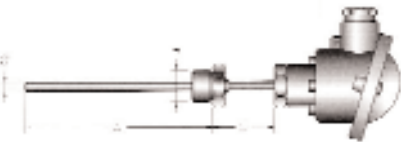

### Type BDTTS

Conventional insulated thermocouple ( TIC ) for direct immersion with connection head, suitable for general measurements and controls on plants with low pressure.



### Type BDTTM

Thermocouple with mineral oxide insulation for direct immersion, with connection head, suitable for general measurements and controls on plants with low pressure and with high vibrations.

**Type BDTTP**

Thermocouple suitable for mounting together with thermowells, for temperature measurements on industrial plants with high pressure.

**Type BDTTH**

Thermocouple for high temperature with ceramic protective tube Ø15mm and connection head.

**Type BDTTV**

Thermocouple for high temperature with double alumina type 710 sheath ( the external one Ø24mm and the internal one Ø15mm) and with connection head.

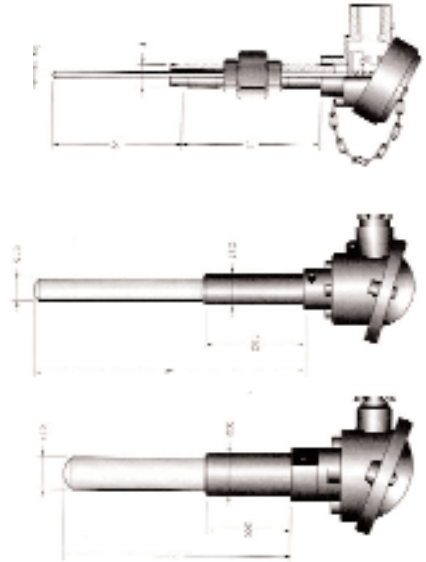

## resistance-elements (RTD)

RTD's are wire wound and thin film devices that work on the physical principle of the temperature coefficient of electrical resistance of metals. They are nearly linear over a wide range of temperatures and can be made small enough to have response times of a fraction of a second. They require an electrical current to produce a voltage drop across the sensor that can be then measured by a calibrated read-out device.

### Traditional insulated thermo-elements

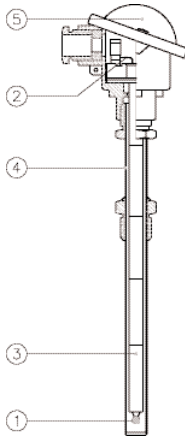

#### 1) sensitive element

the sensitive element is the most important part of the RTD, a poor quality sensitive element would jeopardize the correct functioning of the entire sensor. Sensitive elements with different degrees of accuracy and with single or dual elements are available.

#### 2) connection wires

the resistance thermometer is available in a two/three or four wire execution.

#### 3) ceramic insulator

ceramic insulators prevent short circuits and insulate the connection wires from the protective sheath.

#### 4) powder filling

the filling powder is an extremely fine alumina powder, filled by a vibration unit, dried and vibrated, which fills any gap. In this way the sensor can withstand process vibrations.

#### 5) protective sheath

the protective sheath is designed to protect and isolate the thermocouple from the process. A correct choice of materials and thickness is important against process conditions. In certain conditions it is recommended to use thermowells.

#### 6) connection head

the connection head contains the wiring terminals made of ceramic insulating material. Depending on the conditions an Ex proof execution can be supplied. A built in 4-20 mA transmitter is available, this can be mounted instead of the ceramic block.

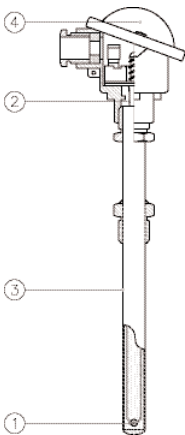

### MgO mineral insulated thermo-elements

#### 1) sensitive element

special techniques are used to connect the internal connectors embedded in mineral oxide to the sensitive element. To meet different requirements the mineral insulated cable is available in a single or a double sensitive measuring element.

#### 2) connection wires

available are two, three or four wire executions.

#### 3) mineral insulated

sheath this consists of a metal sheath containing the conductors which are insulated from each other and from the sheath itself by extremely pure and highly compressed metal oxide. Standard magnesium oxide (MgO) is used for isolation.

#### 4) connection head

the connection head contains the wiring terminals made of ceramic insulating material. Depending on the conditions an Ex proof execution can be supplied. A built in 4-20 mA transmitter is available, this can be mounted instead of the ceramic block.

### Type BDRLF

RTD with stainless steel point to measure temperatures in food etc.

### Type BDRMF

RTD with stainless steel point to measure temperatures in food etc.

### Type BDRLB

RTD to measure surface temperatures on pipes, tanks etc.

### Type BDRIS

Interchangeable RTD insert with standard insulation suitable for use in assembly type BDRTG etc.

### Type BDRIM

Interchangeable RTD insert with mineral oxide MgO insulation suitable for use in assembly type BDRRG etc.

### Type BDRTG

RTD for direct immersion with interchangeable RTD insert ( type BDTIS ) and revolving connection head suitable for measurements and controls on plants with low pressure.

### Type BDRRG

Immersion RTD with interchangeable MgO insulated RTD insert ( type BDTIM ), revolving connection head and tapered protective sheath for fast response time, for measurement and controls on plants with low pressure.

### Type BDRTF

RTD for immersion with interchangeable thermocouple insert ( type BDTIS ) and revolving connection head for measurements and controls on plants with low pressure.

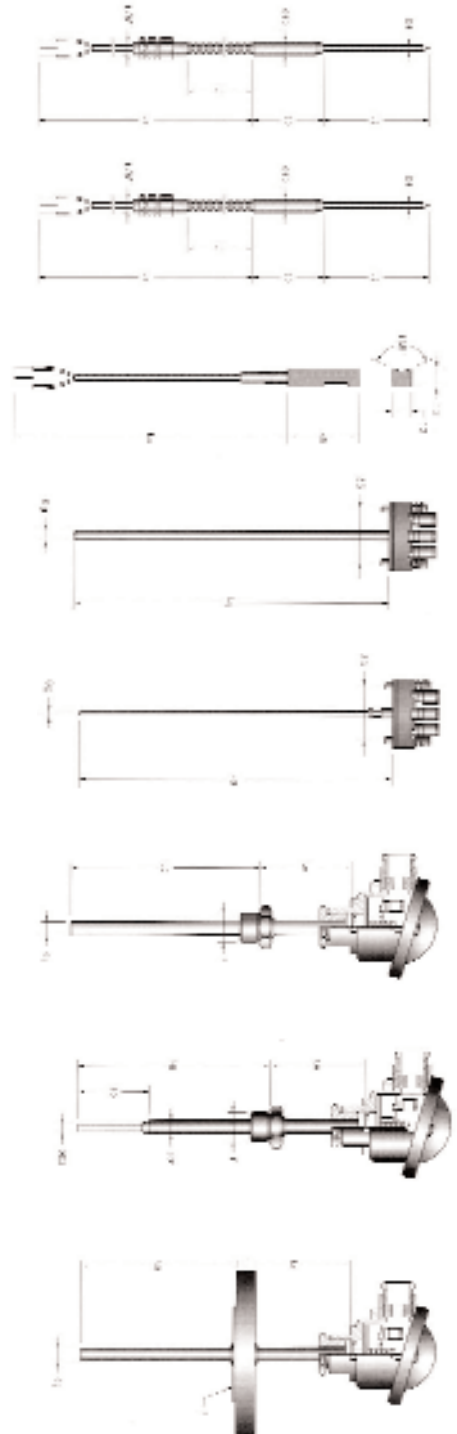

## resistance-elements (RTD)

2.2.1.



### Type BDRLM

Cylindrical RTD with AISI304 sheath suitable for general measurements and controls.



### Type BDRMM

Cylindrical RTD with stainless steel sheath and with compact mineral oxide ( MgO ) insulation.



### Type BDRLR

Cylindrical RTD with AISI 304 sheath suitable for general measurements and controls. The fixing is done by means of a threaded connection welded on the sheath.



### Type BDRROT

RTD with stainless steel sheath suitable for general measurements and controls. The sensor fixing is done by means of a brass ring soldered on the tip of the tube.

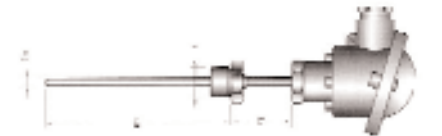

### Type BDRTS

RTD for direct immersion with connection head, suitable for general measurements and controls on plants with low pressure.



### Type BDRTM

RTD with mineral oxide insulation for direct immersion, with connection head, suitable for general measurements and controls on plants with low pressure and with high vibrations.



### Type BDRBA

Spring-loaded RTD designed for measurements into metallic plates; the mounting is done by threaded connection with bayonet fitting.



### Type BDRBS

Spring-loaded RTD for measurements into metallic plates, the mounting is done by a threaded connection with bayonet fitting; this probe is especially designed for spots with space problems.

**Type BDRRF**

Immersion RTD with MgO insulated interchangeable RTD insert ( type BDTIS ), revolving connection head and tapered protective sheath for fast response time, for measurements and controls on plants with low pressure.

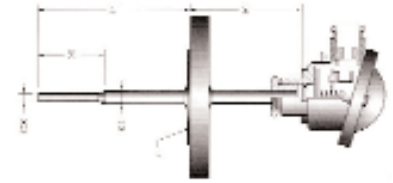

**Type BDRTI**

RTD suitable for mounting together with thermowells ( see page 152, 153, 154 ), for temperature measurements on industrial plants with high pressure.

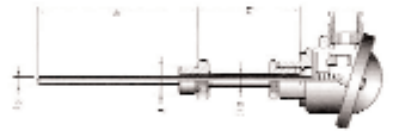

**Type BDRTP**

RTD suitable for mounting together with thermowells, for temperature measurements on industrial plants with high pressure.

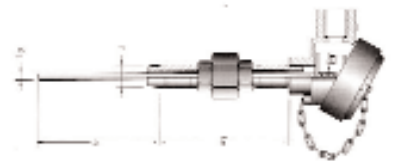

**Type BDRTA**

RTD for direct immersion with AISI316 sheath suitable for temperature measurement in chemical and / or food industry.

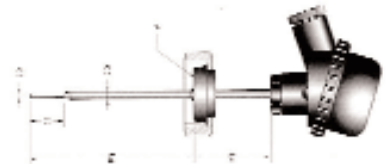

**Type BDRAL**

RTD probe for the measurement of internal and external ambient temperatures build in an aluminium casing.

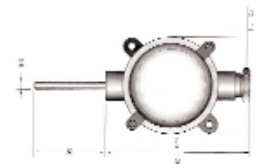

**Type BDRAB**

RTD probe for the measurement of internal room temperatures build in plastic casings.

