

chemical seal BF flush diaphragm, flanged type

typical "BF" seal applications

- to combine with industrial process transmitters.
- to combine with mechanical pressure gauges.
- to combine with pressure switches.

technical specification model BF

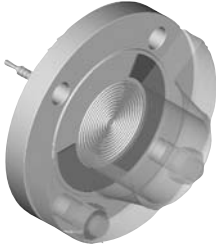

Flanged connection	1"	1 1/2" / 2"	2"	3"	3" / 4"
ASME					
DIN	DN25	DN40/50	DN50	DN80	DN80/100
Diaphragm size in mm	32	44	57	72	89
Max. process pressure in bar at 20 °C	414	414	414	414	414
Max. capillary length in meter	6	10	15	15	15
Min. pressure range for PI in bar	2.5	1.6	0.6	0.5	0.5
Min. span for GP & AP in mbar	4000	1250	600	200	80
Min. span for DP in mbar	n.a.	300	100	20	10

Process connection	Standard	Options
ASME B 16.5	1" / 1 1/2" / 2" / 3" / 4"	Other sizes acc ASME
	150 / 300 / 600#	> 600#
	RF	FF, groove, RJ, RTJ
	Ra 3.2...6.3 µm	Other finishes
DIN 2501 (EN 1092-1)	DN25 / 40 / 50 / 80 / 100	Other sizes acc DIN
	PN10 / 25 / 40	> 40 bar
	Form D-DIN2526, (Form B1)	Other types and finishes
JIS		On request

Wetted parts	Standard	Options
Flange	AISI316 (L)	Custom design
Diaphragm(weld in process)	AISI316L	

Instrument connection	Standard	Options
Capillary tubing	Top entry	Side entry
Threaded	1/2 bsp female	Other sizes

Features	Standard	Options
Capillary tubing	AISI316	Side entry
Armoring	PVC sleeve black	Polyolefin sleeve black
	AISI304 Polyolefin sleeve white	
Filling fluid	BSO22 (FDA app.)	Others see page 171
Diaphragm	AISI316L	On request
Temperature reducer		All instruments except DP
Temperature compensator		All instruments except PI
Full welded construction		All instruments
Flushing rings		For all DIN, ANSI flanges
Support handle		On all flanges above 600#
Support pipe		Heavy duty pipe on capillary
BAsecal calculation		All transmitters with seals
Calibration on process conditions		All instruments
Hydrogen applications	Gold coating	All AISI316 diaphragms
Special coatings		PTFE, FEP, ECTFE, PFA

minimum ranges for gauges and transmitters per diaphragm

Diaphragm diameters dD For process connections			Min. span in mbar For transmitters			Min. range in bar For pressure gauges PI		
Diaphragm	Flange	Flange	GP	AP	DP	Ø 63	Ø 100	Ø 160
44 mm	DN50	2"	1250	1250	300	1.6	1.6	1.6
57 mm	DN50	2"	600	600	100	0.6	0.6	0.6
72 mm	DN80	3"	200	200	20	0.5	0.5	0.5
89 mm	DN80	3"	80	80	10	0.5	0.5	0.5
89 mm	DN100	4"	80	80	10	0.5	0.5	0.5

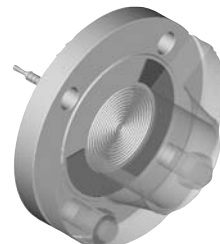

temperature effect on transmitter, capillary and seal

Diaphragm diameters dD For process connections			Temp. effect in mbar For DP transmitters			Temp. effect in mbar For GP /AP transmitters		
Diaphragm	Flange	Flange	DP	Seal	Cap / mtr	GP/AP	Seal	Cap / mtr
44 mm	DN50	2"	0.20	1.24	2.28	1.90	4.90	10.3
57 mm	DN50	2"	0.15	0.66	0.63	1.70	2.65	3.9
72 mm	DN80	3"	0.10	0.24	0.20	0.55	0.95	1.2
89 mm	DN80	3"	0.04	0.09	0.08	0.19	0.39	0.4
89 mm	DN100	4"	0.04	0.09	0.08	0.19	0.39	0.4

Temperature effect is per +10 °C and measured from 20 °C.

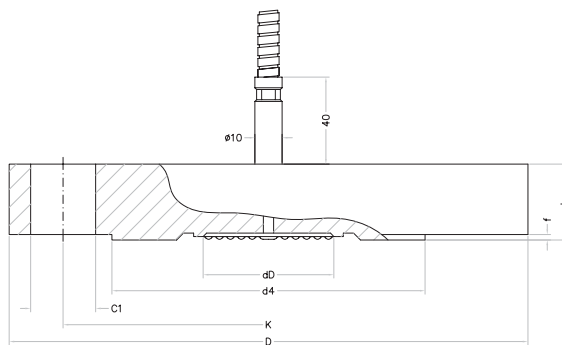

Capillary execution

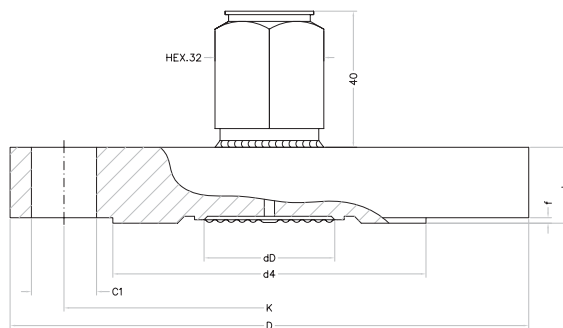

Threaded execution